



## LIQUID LEVEL SWITCH LLS-SERIES

- HIGH/LOW LIQUID LEVEL PROTECTION FOR GAS COMPRESSOR SCRUBBERS, DEHYDRATION UNITS, AND OTHER APPLICATIONS
- DUAL CHAMBER DESIGN TOTALLY ELIMINATES ALL LEAKAGE AND EXPOSURE OF SWITCH OR WIRING TO LIQUIDS
- CONSTRUCTED OF STAINLESS STEEL COMPONENTS FOR SUPERIOR CORROSION RESISTANCE
- DIRECTLY REPLACES TRADITIONAL LEVEL SWITCHES, INCLUDING THE L1200
- CSA CERTIFIED FOR USE IN CLASS I, DIVISION 1 AND 2, GROUPS C AND D HAZARDOUS AREAS

The Altronic LLS represents the next generation in liquid level protection for gas compressor scrubbing and dehydration units as well as other applications. Featuring a unique isolated cavity for the electrical switch and wiring, the design of the LLS eliminates the possibility of leakage and liquid contamination of the electrical switch and connections— the leading cause of premature failure of similar float switches currently in service.

This high-quality, all stainless-steel, float-activated design is equipped with a 2" NPT threaded connection for direct installation into the wall of the pressure vessel or weld collar or can be adapted for use in conjunction with an external float chamber. As condensate or other liquids rise or fall within the monitored vessel (scrubber), the float/arm assembly on the "wet" side of the LLS deflects and moves an arm, causing the single pole, double-throw micro-switch in the "dry" side to trip. The connection between the two cavities is a magnetic field and requires no ports or wiring orifices. Both low and high level monitoring applications can be accommodated through the use of the appropriate micro-switch contacts within the device.

The Altronic LLS Level Switch is designed as an explosion-proof device and is certified by CSA for use in Class 1, Division 1 and 2, Groups C and D hazardous areas. Designed to meet industry-standard mounting and installation specifications (body size and threads), the LLS can be used as a replacement for existing single-cavity level switch designs, including the L1200.



CLASS I, DIVISION 1 AND 2,  
GROUP C AND D

## DIMENSIONS

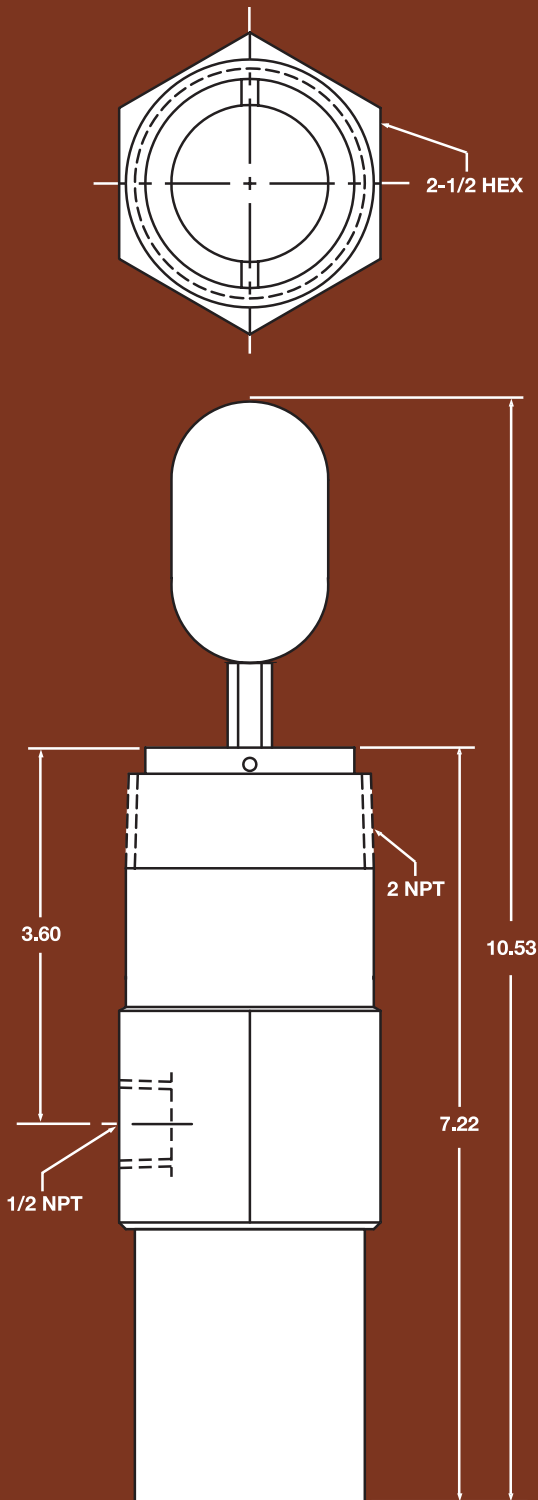

## SPECIFICATIONS

POWER REQUIREMENT ..... NONE - PASSIVE SWITCH

HAZARDOUS AREA RATING ..... CLASS I, GROUPS C&D,  
DIV.1 AND 2

MAXIMUM STATIC  
OPERATING PRESSURE ..... 1500 psig (10.3 Mpa)

MAXIMUM TEMPERATURE  
OF MONITORED LIQUID ..... 257°F (125°C)

### MATERIALS

BODY AND COVER, FLOAT ..... STAINLESS STEEL

SWITCH CONTACTS ..... SPDT (N/O, COMMON, N/C)

OUTPUT SWITCH RATING ..... 11 Amps (Resistive)  
at 125-277 VAC

4 Amps (Inductive)  
at 125 VAC

0.5 Amps at 125 VDC

## TO ORDER

LIQUID LEVEL SWITCH, LLS SERIES ..... 690050-1

**altronic<sup>®</sup>  
inc.**

712 TRUMBULL AVE. / GIRARD, OH 44420  
(330) 545-9768 / Fax: (330) 545-9005  
www.altronicinc.com E-mail: sales@altronicinc.com

Form LLS 7-05 ©2005 Altronic, Inc.